

Ziegler

Redefine Innovative Metering

AC Voltage Relay With Adjustable Time Delay

Protector Trip Relay Series
ANSI No. 27/59



© Ziegler Instruments Order No. AC Voltage Relay With Adjustable Time Delay Data sheet-EL.R0-920826-46-2013-EN



Models available

| Function / System | Product Type |
|-------------------------------|--------------|
| Single Phase, Under voltage | 252-PVZ |
| Single Phase, Over voltage | 252-PVH |
| 3 Phase 4 wire, Under voltage | 252-PVX |
| 3 Phase 4 wire, Over voltage | 252-PVS |
| 3 Phase 3 wire, Under voltage | 252-PVJ |
| 3 Phase 3 wire, Over voltage | 252-PVC |

Applications

The Protector can be used to protect for:-

- Under voltage.
- Over voltage.
- Start up standby generators.
- Operation of mains failure units.
- Switching standby hybrid supplies.
- Protecting computer supplies.
- Where close control is required.
- Gensets - to monitor correct operation of the AVR (Automatic voltage regulator) and excitation system
- Motors-Some electric motors are voltage sensitive, and can overheat and burn out when operated at low voltage
- UPS supplies - When the main A. C. supply falls outside the acceptable operating voltage window, the relay can initiate a change over to an alternate or standby supply

Features

- Adjustable setpoint
- Adjustable time delay
- Internal differential (factory settable)
- LED trip indication
- 2 pole relay contacts
- Energize/De-energize function swapping
- Auto Reset

Introduction

Voltage Protectors provide continuous surveillance of the monitored circuit. When the measured voltage moves outside the setpoint limit, the relay will operate after the selected time delay, giving an alarm and or initiation signal. Relays normally energise on over volts and de-energise on under volts. An illuminated LED indicates when the relay is energised. 3 phase 3 or 4 wire models protect each phase independently.

Specifications

Input

| | |
|------------------|---|
| Nominal Voltage | : 100, 110, 220, 230, 240, 380, 400, 415 or 440V (57 to 480V) |
| System Frequency | : 50/ 60/ 400Hz |
| Voltage Burden | : 0.3VA |

Overload : 1.2 x rating continuously
1.5 x rating for 10 seconds, acc. to BS 6253

Setpoint

Repeatability : > 0.5% of full span

Differential: : Preset at 1%
Other values 1% to 10% (Available on request)

Range : Under Voltage 75 to 100%
Over Voltage 100 to 125%
Of nominal input voltage

Time Delay : Adjustable up to 10 sec
max 30 sec

Aux. Voltage Burden : 4VA (max)

Output relay

Type: D.P. Changeover

Rating A.C : 240V, 5A non - inductive
D.C : 24V 5A resistive

Operations : 0.2 million at the above loads

Reset : Automatic

Other Specifications

Operating temperature : 0°C to +60 °C

Storage temperature : -20°C to +70 °C

Temp. co-efficient : 0.05% per °C

Interference immunity : Electrical stress surge withstand and non function to ANSI/IEEE C37 90a

Enclosure style : DIN-rail with wall mounting facility

Material : Flame retardant polycarbonate /ABS

Enclosure integrity : IP 50

Model 252 dimensions : 55mm(2.2")wide x 70mm(2.8")H x 112mm (4.4") deep

Weight : 252 case - approx 0.4Kg
253 case - approx 0.6Kg

Product Function

Over Voltage models :

When the monitored voltage exceeds the setpoint, the time delay is started. When the time has elapsed, the relay will energise and the red LED will illuminate to indicate the trip condition. The relay will automatically reset once the monitored voltage falls below the setpoint minus the differential. When reset, the LED will extinguish and the relay de-energises. The time delay is not active when resetting.

Under Voltage models :

When the monitored voltage falls below the setpoint, the time delay is started. When the time has elapsed, the relay will de-energise and the red LED will extinguish to indicate the trip condition. The relay will automatically reset once the monitored voltage rises above the setpoint plus the differential. When reset, the LED will illuminate and the relay energizes. The time delay is not active when resetting. On request, any product can be manufactured with the energize / de-energize function swapped.

Options

- Adjustment ranges – different adjustment ranges are possible for the set point and time delay controls.
- Separate auxiliary supply – sometimes required to maintain a time delay.
- Differential – internally fixed value between 1% and 15%.
- Relay operation – standard models are fail safe, but the relays can be customised to energise or de-energise on trip.

Connection diagrams

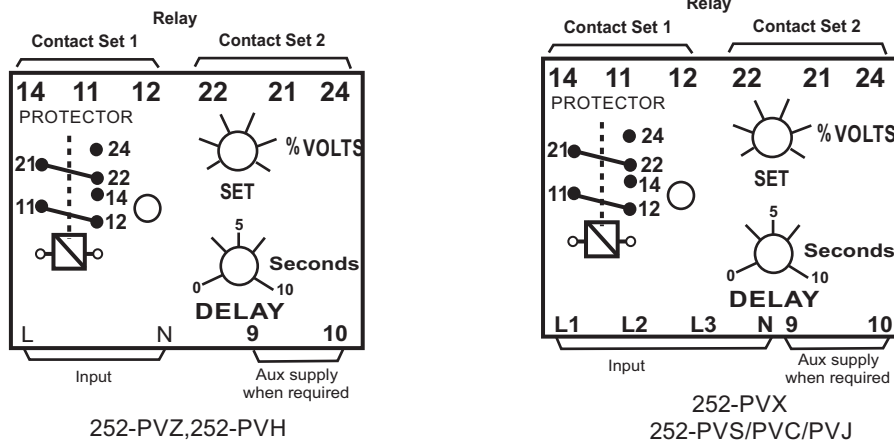

Note : The neutral connection is always used on 4 wire system

Dimensions

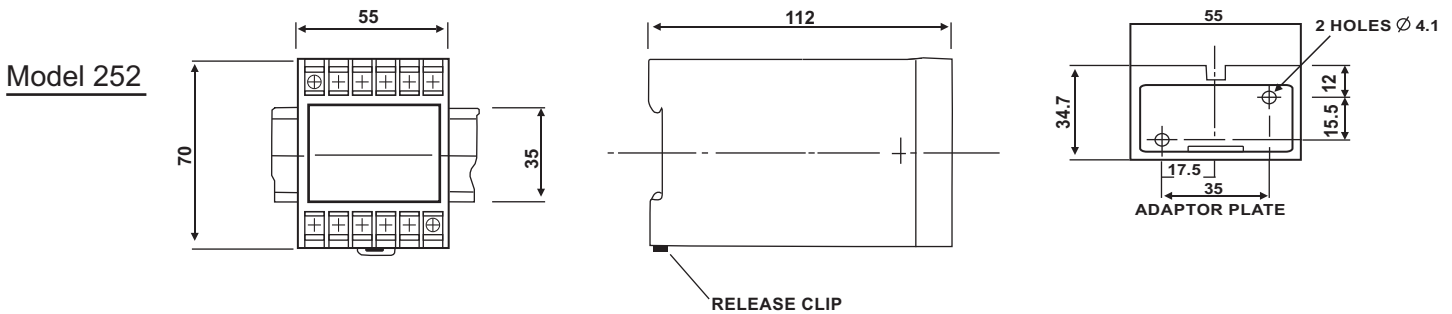

Ordering Information

Please quote :

1. Product Type.
2. Function i.e. Under or Over.
3. Relays normally de - energise on under trip and energise on over trip.
4. Please specify standard or non standard trip. An energised relay is indicated by a "Lit" red LED. Setpoint can be factory adjusted to your requirements.
5. System Voltage and/or Current where applicable.
6. System Frequency.
7. Auxiliary Voltage where required.
8. Preset Differential where required.
9. Time delay where applicable.

ZIEGLER INSTRUMENTS

Schnepfenreuther Weg 6, D-90425 Nürnberg, Germany.

TEL. | (+49)(911) 38 492 45 | E-MAIL | info@ziegler-instruments.com
 FAX. | (+49)(911) 32 26 212 | WEBSITE | www.ziegler-instruments.com

made
in
Germany

Ziegler

Redefine Innovative Metering